

Modern Slavery Statement

2025

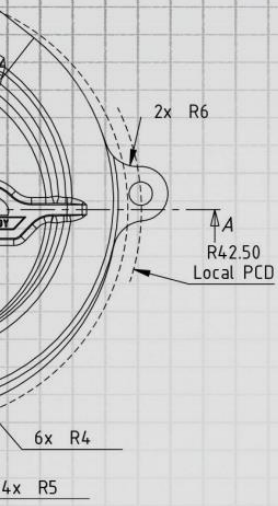
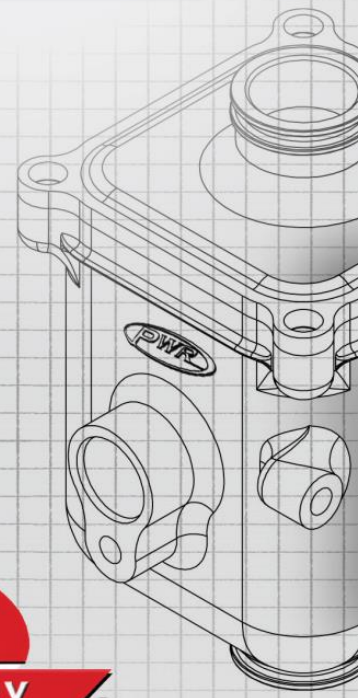
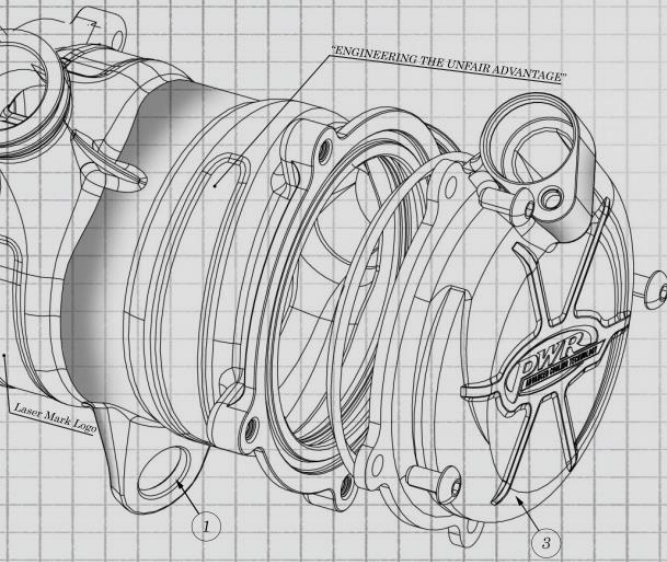

The Global Leader in Cooling Technology

Inspired by Engineering Excellence

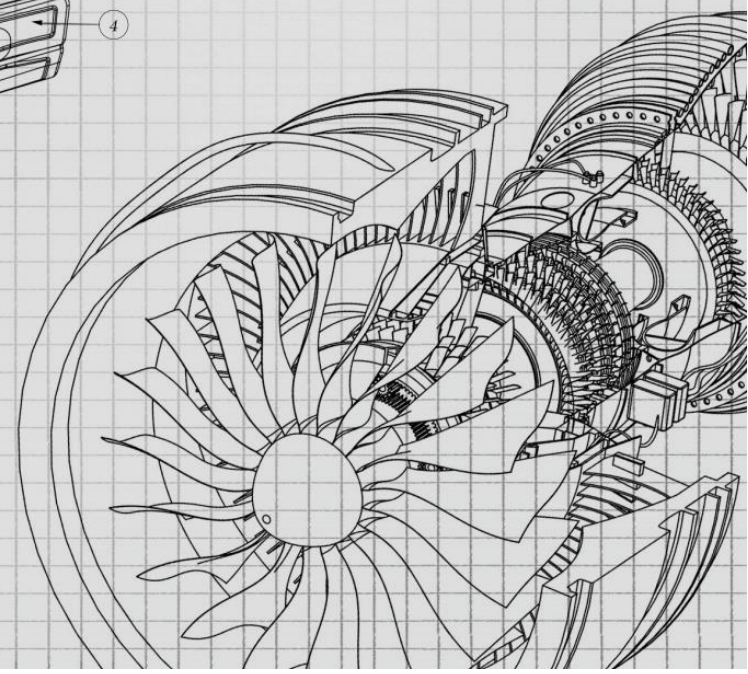
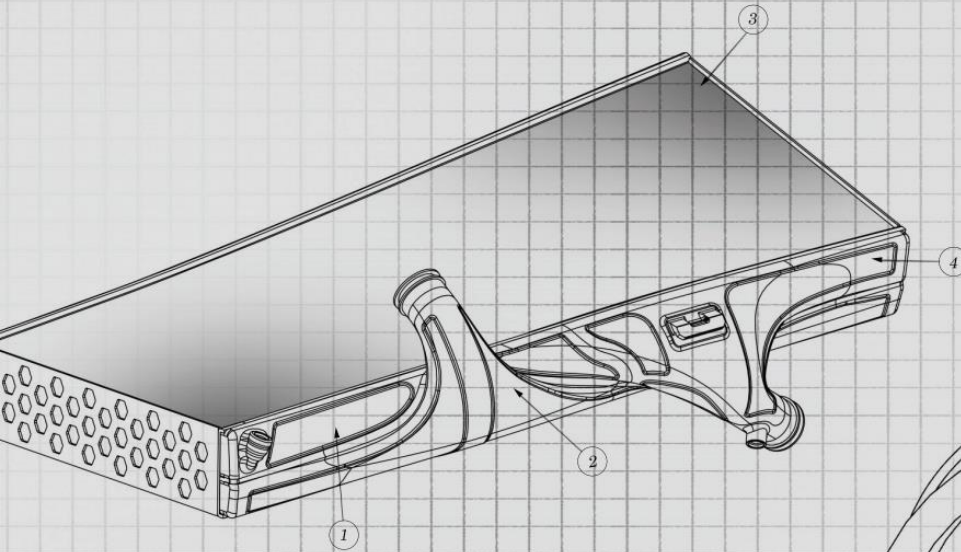

Introduction

This Modern Slavery Statement (“**Statement**”) sets out the actions taken by PWR Holdings Limited (ABN 85 105 326 850) and its subsidiaries (together “**PWR**”) to address modern slavery risks in our business and supply chains. The Statement has been prepared in accordance with the Australian *Modern Slavery Act 2018* (Cth) and the United Kingdom *Modern Slavery Act 2015* (UK).

This is the fourth Statement made by PWR and relates to the year ending 30 June 2025.

PWR opposes modern slavery in all its forms, including human trafficking, slavery, servitude, forced labour, debt bondage, forced marriage and child labour. We recognise the role of business in understanding, addressing and mitigating modern slavery risks, and are committed to working with our employees, suppliers and contractors to identify and address modern slavery risks.

Lodgement

Under the Australian *Modern Slavery Act 2018* (Cth), companies are required to lodge their Modern Slavery Statement when group revenue is A\$100 million or greater. PWR exceeded the reporting threshold for the financial year ended 30 June 2022 and remains above the reporting threshold for the year ended 30 June 2025. PWR has lodged this Statement as required under the Australian legislation.

Under the *Modern Slavery Act 2015* (UK), companies are required to lodge their Modern Slavery Statement when group revenue is GB£36 million or greater. PWR exceeded the reporting threshold for the financial year ended 30 June 2021 and remains above the reporting threshold for the year ended 30 June 2025. PWR has lodged this Statement as required by the UK legislation.

The Statement has been published on the PWR website (www.pwr.com.au/investors/corporate-governance).

Structure, operations and supply chains

PWR is a global designer, manufacturer and supplier of advanced cooling solutions that invests in research and development to provide technically advanced solutions to its customers. We adopt a flexible manufacturing approach and take pride in supporting our customers through a truly unique system of technical partnership.

PWR Holdings Limited is the parent entity, headquartered in Stapylton, Queensland, Australia, and listed on the Australian Stock Exchange (ASX:PWHL). This Statement is on behalf of PWR Holdings Limited and the following wholly-owned subsidiaries:

- P.W.R Performance Products Pty Ltd (Australia)
- PWR IP Pty Ltd (Australia)
- PWR Europe Limited (United Kingdom)
- C&R Racing, Incorporated (United States of America)

PWR manufacturing and distribution facilities are located in Stapylton (Australia), Rugby (United Kingdom) and Indianapolis (United States of America). PWR sources raw materials, components and services from a wide range of suppliers across multiple countries.

The PWR supply chain consists of 1,252 suppliers across 21 countries for a total spend of A\$74.2m. The majority of the suppliers by number and spend are located in Australia and the United States of America.

Our supply chain can be divided into the following segments:

- **Raw materials** – predominately aluminium billet, coil, plant and extruded tubing;
- **Equipment** – machinery utilised in the manufacturing processes;
- **Transport** – road, air and sea freight for inward movement of supplies and dispatch of finished goods;
- **Other Services** – including IT services, maintenance services, and professional services; and
- **Other Goods** – including uniforms, manufacturing consumables, and utilities.

FY25 Supply Chain

1,252 suppliers

21 countries

A\$74.2m spend

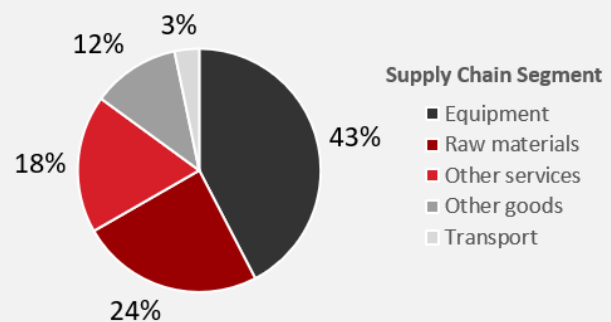
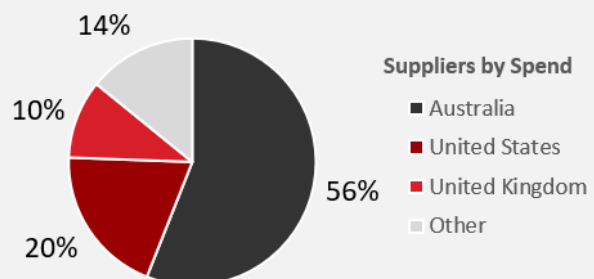

Risks of modern slavery practices in our operations and supply chains

In our operations

We consider modern slavery risk in our operations to be low due to the following:

- PWR operates in Australia, United Kingdom, and the United States of America, all of which are ranked low in the country Global Slavery Index;
- PWR employees are covered by modern awards or individual employment contracts that set the minimum pay and conditions; and
- PWR maintains transparent operations supported by its governance framework and policies including its Whistleblower Policy to encourage employees to raise concerns.

As at the date of this Statement, no reports of modern slavery have been received.

In our supply chains

PWR has less visibility into the operations of our suppliers and contractors. To identify potential modern slavery risks in our supply chains and to focus our actions, we undertook a risk assessment of our existing and new suppliers taking into account the following:

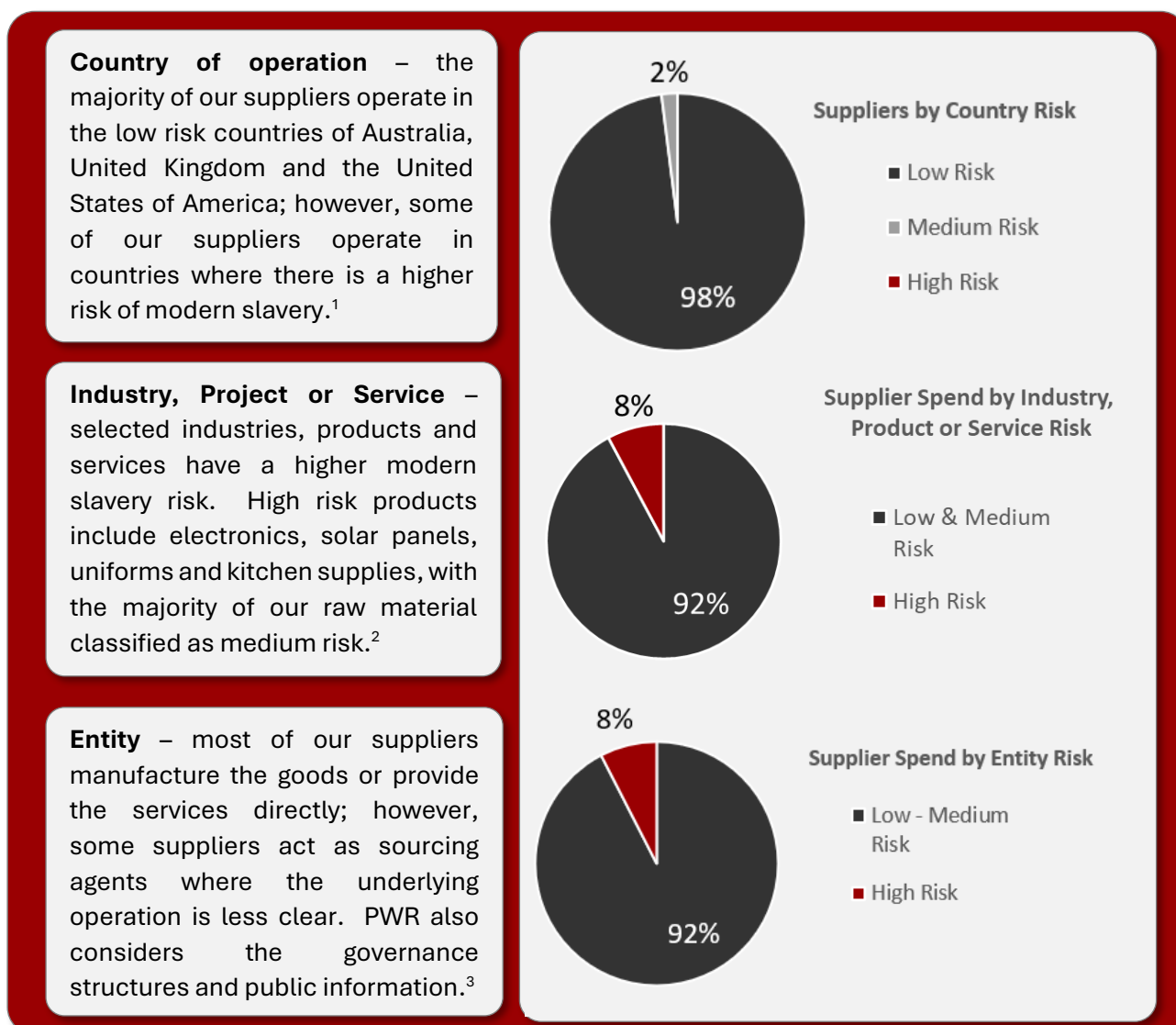

¹ Walk Free 2023, Global Slavery Index 2023. Available from: <https://www.walkfree.org/global-slavery-index/>

² Global Slavery Index 2023 – Appendix 3 – List of products at risk

³ Australian Border Force Modern Slavery Infographic

Actions taken to assess and address these risks including due diligence and remediation processes

Due Diligence

PWR adopts a risk-based approach to modern slavery due diligence. This includes imbedding the modern slavery risk assessment as part of a new supplier evaluation. Based on the results of our supplier risk assessments, we identify suppliers with a higher risk for modern slavery. Further due diligence is undertaken to assess the modern slavery risks, including engaging directly with the high risk suppliers to better understand their structure and sourcing practices, together with their approach to managing modern slavery risk. If the modern slavery risk remains high after engaging with a supplier, we will remove the supplier from the approved supplier list and cease future trade.

Policies

We implemented a Modern Slavery Policy and integrated such requirements into corporate policies and purchasing documentation including:

- Purchasing Policy;
- Whistleblower Policy;
- Code of Conduct; and
- Standard Terms and Conditions of Purchasing.

Training

The executive leadership and procurement teams undertook Modern Slavery Awareness training.

Remediation Processes

Any modern slavery incidents or breaches will be managed through the existing incident reporting, investigation and corrective action processes. As at the date of this Statement, no incidents or breaches have been reported.

Actions

The following is an update on completed and proposed actions to further embed the modern slavery risk management into PWR's governance framework and systems:

| 2025 Actions | Status |
|--|---------------|
| Continue modern slavery awareness training for roles that support procurement | Ongoing |
| Implement supplier modern slavery status within the ERP system. | Complete |
| Introduce a Supplier Code of Conduct outlining PWR's standards that all existing, and newly onboarded, suppliers must agree to. | Complete |
| Integrate checks on tier two suppliers to ensure PWR's standards are upheld throughout the supply chain. | Early Stage |
| Ongoing assessment to prequalify new suppliers and monitoring of existing suppliers that may include review of risk assessments, audits, investigations and support to mediate identified non conformances | Ongoing |
| Continue to review and update policies and procedures as required to support the management of modern slavery risks as part of our Risk Management Framework | Ongoing |

2026 Proposed Actions include:

- Assess the effectiveness of the Modern Slavery policies and adapt the Statement and PWR's approach accordingly;
- Continue modern slavery awareness training for roles that support procurement;
- Update and maintain supplier modern slavery ratings within the ERP system;
- Annually review the Supplier Code of Conduct outlining PWR's standards to which all existing, and newly onboarded, suppliers must agree; and
- Integrate checks on tier two suppliers to ensure PWR's standards are upheld throughout the supply chain.

Assessing the Effectiveness of Our Actions

We recognise that preventing modern slavery requires more than implementing actions – it requires measuring whether those actions are working. We assess the effectiveness of our approach through a combination of quantitative metrics, qualitative feedback, and regular review cycles.

Due diligence

We measure effectiveness by tracking the percentage of high-risk suppliers assessed each year, the number and severity of risks identified and the proportion of risks remediated within agreed timeframes. Supplier risk profiles are compared year-on-year to identify improvement trends. Where practical, we validate our findings through independent audits or peer benchmarking.

Policies

We monitor policy effectiveness through compliance audits, supplier contract reviews and by tracking that confirmation rates of staff having read and understood the policies. Policies are reviewed annually with changes made in response to identified gaps or emerging risks.

Training

Effectiveness is assessed through completion rates, post-training knowledge checks and participant feedback. We also monitor the quality and volume of modern slavery risk reports and supplier questionnaires after training as an indicator of increased awareness and capability.

Remediation processes

We assess timeliness of responses, the proportion of cases resulting in meaningful remedy for affected individuals and whether corrective actions prevent recurrence. Outcomes are reviewed with input from internal stakeholders and, where appropriate, external experts.

Update Risk Assessment

The risk assessment for existing suppliers will be updated as new information becomes available. As we engage with suppliers to improve our understanding of the supply chain, we anticipate that the risk rating for selected suppliers may reduce.

Audit, Risk and Sustainability Committee

We review these measures and the effectiveness of managing modern slavery risks at least annually, including progress for implementing actions. Responses to any reports of modern slavery concerns are reported to PWR's Audit, Risk and Sustainability Committee.

Consultation and approval processes

The executive leadership team, including senior leaders responsible for all PWR entities have been consulted in the preparation of this Statement and the associated actions. The executive leadership and their teams will continue to be consulted regarding identified risks and involved in the implementation of further actions, including any investigations and remediation actions.

PWR is strongly committed to upholding all human rights and employees' rights, and fully supports both the Australian and United Kingdom Governments in their efforts to eliminate modern slavery. We expect our suppliers, contractors and other stakeholders to join us in our approach.

This Statement has been approved by the Board of PWR Holdings Limited.



Matthew Bryson
Acting Chief Executive Officer
PWR Holdings Limited
20 November 2025



PWR HOLDINGS LIMITED

ABN 85 105 326 850

COMPANY SECRETARY

Alexandra Coleman

PRINCIPAL REGISTERED OFFICE

PWR Holdings Limited

28 Quarry Road
Stapylton, 4207
Queensland
Phone: 07 5547 1600
Fax: 07 5547 1666
Email: info@pwr.com.au

POSTAL ADDRESS

PO Box 6425
Yatala QLD 4207

NORTH AMERICA

**PWR North America
(C&R Racing)**

6950 Guion Road
Indianapolis, IN 46268
USA
Phone: +1 317-293-4100
Fax: +1 317-293-4110
Email: info@pwrna.com

EUROPE

PWR Europe

Unit C, Valley Point, Valley Drive
Swift Valley Industrial Estate
Rugby, Warwickshire CV21 1TN
United Kingdom
Enquiries
Phone: +44 (0) 1327 362940
Fax: +44 (0) 1327 362960
Email: sales@pwreurope.com

WEBSITE

www.pwr.com.au

LOCATION OF SHARE REGISTRY

Computershare Investor Services Pty Ltd

Level 1, 200 Mary Street
Brisbane, 4000
Queensland

ASX TICKER CODE:

PWH

