



# MODERN SLAVERY STATEMENT

FY 2023 Fantech Pty Ltd



**FANTECH**  
Intelligent Ventilation

# CONTENTS

<b>01</b>	Statement Introduction	4
<b>02</b>	Acknowledgment of Country	5
<b>03</b>	Our Commitment	6
<b>04</b>	Our Structure, Operations & Supply Chain	7
<b>05</b>	Identifying Risks of Modern Slavery in Our Supply Chain	14
<b>06</b>	Risk Mitigation, Due Diligence and Remediation Processes	17
<b>07</b>	Assessing the Effectiveness of Our Actions	21
<b>08</b>	Our Plans For Continuous Improvement	22
<b>09</b>	Consultation	23
<b>10</b>	Approval	24

# STATEMENT COMPLIANCE TABLE

MANDATORY CRITERIA FOR MODERN SLAVERY STATEMENTS		Addressed on Page(s)
<b>Criterion 1 &amp; 2</b>	Identify the reporting entity and describe its structure, operations, and supply chains	7-13
<b>Criterion 3</b>	Describe the risks of modern slavery practices in the operations and supply chains of the reporting entity and any entities it owns or controls	14-16
<b>Criterion 4</b>	Describe the actions taken by the reporting entity and any entities that the reporting entity owns or controls to assess and address these risks, including due diligence and remediation processes	17-20
<b>Criterion 5</b>	Describe how the reporting entity assesses the effectiveness of these actions being taken to assess and address modern slavery risks	21
<b>Criterion 6</b>	Describe the process of consultation with any entities the reporting entity owns or controls (a joint statement must also describe consultation with the entity giving the statement and all reporting entities)	23
<b>Criterion 7</b>	Any other relevant information	2-3, 8, 10, 22

# 01

## STATEMENT INTRODUCTION

This Modern Slavery Statement has been produced for FANTECH PTY LTD. This statement supports the reporting requirements of the Modern Slavery Act (Cth) 2018 and outlines how FANTECH PTY LTD have acted to reduce modern slavery risks in its operations and supply chains from 1 July 2022 to 30 June 2023.

We, are committed to maintaining and improving systems and processes to avoid complicity in modern slavery and/or human rights violations related to our own operations, our supply chain, and our services. We recognise modern slavery can occur in many forms, such as forced labour, child labour, domestic servitude, sex trafficking, workplace abuse and human trafficking. In this statement, the terms “modern slavery” encompass the aforementioned forms of coerced, illegal, and immoral labour.

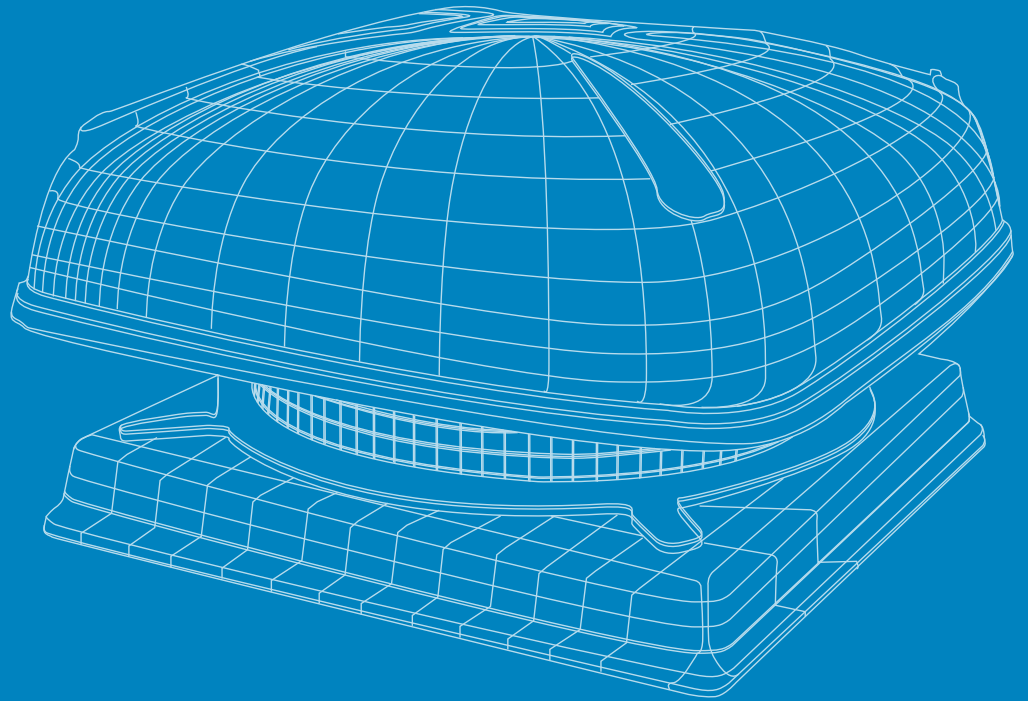

# 02

## ACKNOWLEDGEMENT OF COUNTRY

Fantech acknowledges and pays respects to the Bunurong people of the Kulin Nation, as the Traditional Custodians of the lands and waters our Head Office stands. We pay our respect to the Kulin Nations as the Elders past and present and extend that respect to all Aboriginal and Torres Strait Islander peoples.



# 03

## OUR COMMITMENT

We acknowledge the role we play as a large manufacturer and distributor in Australia and therefore commit to taking steps to prevent and address any involvement in modern slavery and ensuring our policies and practices are meaningful and effective.

Additionally:

1. We support the Australian Government in its drive to end modern slavery and we are dedicated to making a difference in the lives of people impacted by it.
2. We hold ourselves accountable in line with core international business and human rights standards and take actions to identify, prevent and address the risks of modern slavery in our operations and supply chains.
3. We endeavour to partner with suppliers to advocate fair and ethical labour practices, seeking to develop those relationships to understand and educate our supply chains on good practice.

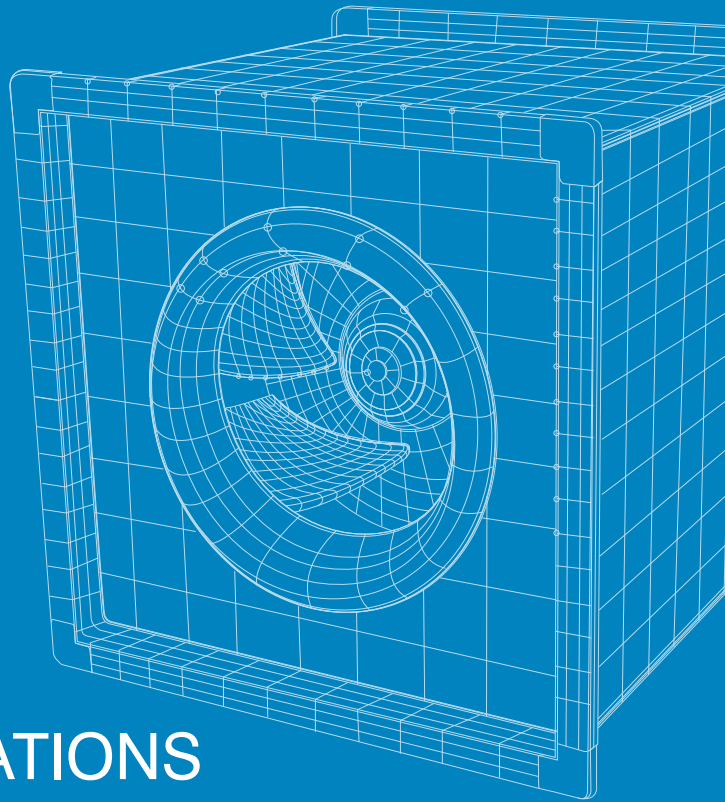

# 04

## OUR STRUCTURE, OPERATIONS & SUPPLY CHAIN

### Reporting Entities

Fantech Pty Ltd (Fantech) the 'reporting entity' (as defined in the Act) covered by this Statement and the terms 'we', 'us' and 'our' refer to the above-mentioned entities (as defined below), except where the context otherwise requires.

Within Australia, Fantech operates in a national scale with offices and sales branches located in most states across the country. Fantech is governed by an executive board with members located in the Head Office, based in Melbourne, Australia. For the purposes of this report, both Fantech Pty Ltd will be referred to as "the company", unless specified otherwise

## Our Values

Our core business values are the base by which we guide our people and operations. All employees are required to keep the company values at the forefront of all dealings with colleagues, customers, suppliers, and contractors.

### Making it Happen

As the world turns, markets change and technologies evolve, we never lose our focus.

### Doing the Right Thing

In everything we do and make, and in the strong relationships we forge, we act ethically and honestly.

### Everyone's Responsible

Family-owned, privately managed, and proudly independent, a sense of individual responsibility, autonomy and entrepreneurship runs throughout our group.

### Trust in Each other

Our success depends on our people, and we are fully committed to them, with a culture of long service throughout the business.

### Thinking Beyond

We are a group of businesses with respect for our founders vision, each of them inspiring us to look ahead and think beyond.



## Our Operations

Across our business' Fantech, we source, manufacture, and sell products with regard to air movement and ventilation. We have been accredited under ISO9001 since 1992 and more recently ISO9001:2015 - Quality Management System, Fantech maintains high standards of manufacturing and a continuous improvement culture. With modern HVAC manufacturing plants in Melbourne, Sydney and Brisbane and warehouses throughout Australia and New Zealand, we provide unmatched delivery performance and customer service.

The business' head office is located at 63 Vision Street, Dandenong South, VIC, 3175, with additional branches and operations located in New South Wales, Victoria, South Australia, Western Australia, Queensland, and the Northern Territory.

Our operations include:

- Product Development
- Product Sourcing
- Product Manufacturing
- Product Distribution
- Product Importing, Re-sale and Distribution
- Product Quality Assurance, Safety and Compliance

These operations are supported by a range of standard supplementary functions including, but not limited to, procurement, purchasing, IT, sales, marketing, engineering, human resources, and finance.

Across our business we employ over 300 people per the below breakdown:

## Employee Location

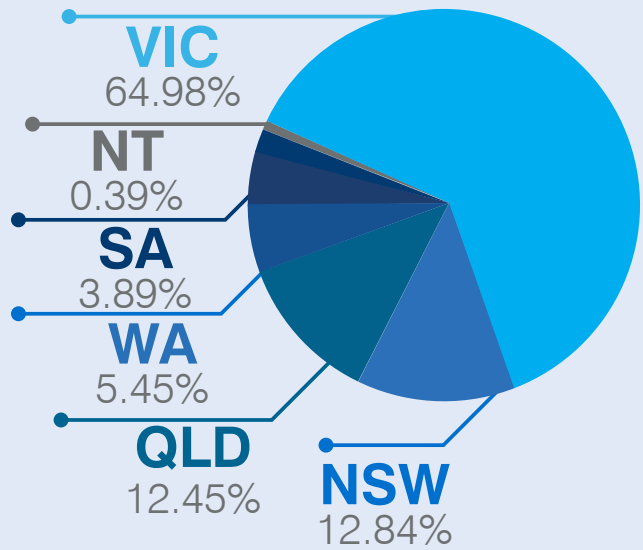

## Employee Classification

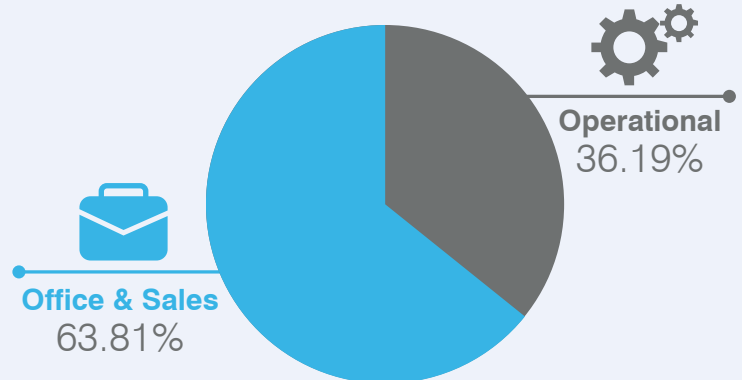

# Quality Management System: ISO Accreditation 9001:2015

To ensure consistent quality and customer satisfaction, Fantech has implemented a comprehensive Quality Management System (QMS) in accordance with the ISO 9001:2015 standard. This prestigious accreditation reflects Fantech's commitment to maintaining the highest level of quality in all aspects of its operations and business dealings.

ISO 9001:2015 is an internationally recognised standard for quality management systems. It provides a framework that enables organisations to consistently meet customer requirements, enhance customer satisfaction, and continuously improve their overall performance. This standard emphasises a process-oriented approach to quality management, focusing on risk-based thinking, customer focus, leadership, and engagement of people.

Fantech has undertaken a rigorous implementation process to align its operations with the ISO 9001:2015 standard. The following steps were followed to achieve ISO accreditation:

- 1. Quality Policy:** Fantech established a quality policy that outlines its commitment to quality, customer satisfaction, and continual improvement. The policy serves as a guiding principle for all employees and stakeholders involved in the company's operations.
- 2. Process Mapping:** Fantech identified and documented all key processes within the organisation, including product design and development, procurement, manufacturing, testing, and customer support. This process mapping exercise helped in understanding the interdependencies of various processes and ensuring effective integration.
- 3. Documentation:** Fantech developed a comprehensive set of documented procedures, work instructions, and forms to standardise processes and ensure consistency in operations. These documents serve as a reference for employees, enabling them to perform their tasks efficiently and effectively.
- 4. Risk Management:** Fantech implemented a robust risk management system to identify, assess, and mitigate risks that could impact the quality of its products and services. This proactive approach helps in preventing quality issues and ensuring customer satisfaction.
- 5. Training and Competence:** Fantech prioritised the training and development of its employees to enhance their skills and knowledge. Training programs were designed to ensure that employees are competent in their respective roles and understand their responsibilities towards maintaining quality.
- 6. Monitoring and Measurement:** Fantech established a system for monitoring and measuring key performance indicators (KPIs) to assess the effectiveness of its quality management system. Regular audits, inspections, and testing activities are conducted to identify areas for improvement and take corrective actions when necessary.

Fantech's ISO 9001:2015 accreditation reflects its unwavering dedication to providing superior quality products and services. By adhering to the rigorous requirements of this international standard, Fantech ensures customer satisfaction, continual improvement, and sustained business success. This commitment to excellence positions Fantech as a reliable and trusted provider of ventilation and air movement solutions in the industry.

# Our Policies & Procedures

Our commitment to equality and fairness is reflected across all levels of our organisation. Our policies, procedures and codes of conduct aim to ensure that employees and suppliers are supported in identifying and addressing risks of modern slavery within our supply chains.

## Workplace Policies & Procedures

### Whistleblower Policy

This policy sets out the avenues open to all company personnel who wish to raise issues about whether the company or our employees have complied with applicable laws and other applicable standards of behaviour. This policy is designed to provide a safe and confidential environment for employees to raise any such concerns without fear of reprisal.

### Dispute and Grievance Resolution Policy

This policy sets out the steps encouraged to be taken to resolve any workplace issues or concerns at the earliest opportunity, with open communication and a focus on resolution.

### EEO, Bullying, Discrimination and Harassment Policy

This policy outlines the company expectations with relation to the treatment of others and our dedication to Equal Employment Opportunity in the workplace.

### Code of Conduct

This policy outlines the obligations of the company to our employees and the standards of behaviour and expectations of employees held by the company.

### Workplace Health, Safety and Wellbeing Policy

This policy highlights the important role that each employee plays in maintaining healthy and safe workplaces as well as internal procedure to support in this.

### Employee Onboarding & Induction

Compulsory education modules are required to be completed by employees across our business as a part of our induction and onboarding process. These compulsory education modules include:

- Whistleblowing
- Respect in the Workplace
- Privacy and Confidentiality
- Workplace Health, Safety and Wellbeing
- Dispute, Grievance and Resolution
- EEO, Bullying, Discrimination and Harassment

These education modules provide our employees information to understand their rights and responsibilities as employees of the business.

## Our Supply Chain

Our business imports HVAC equipment, and manufacturing components along with the manufacturing of products predominately at our head office in Dandenong South.

The business imports both finished and non-finished goods from suppliers as set out on the below map:

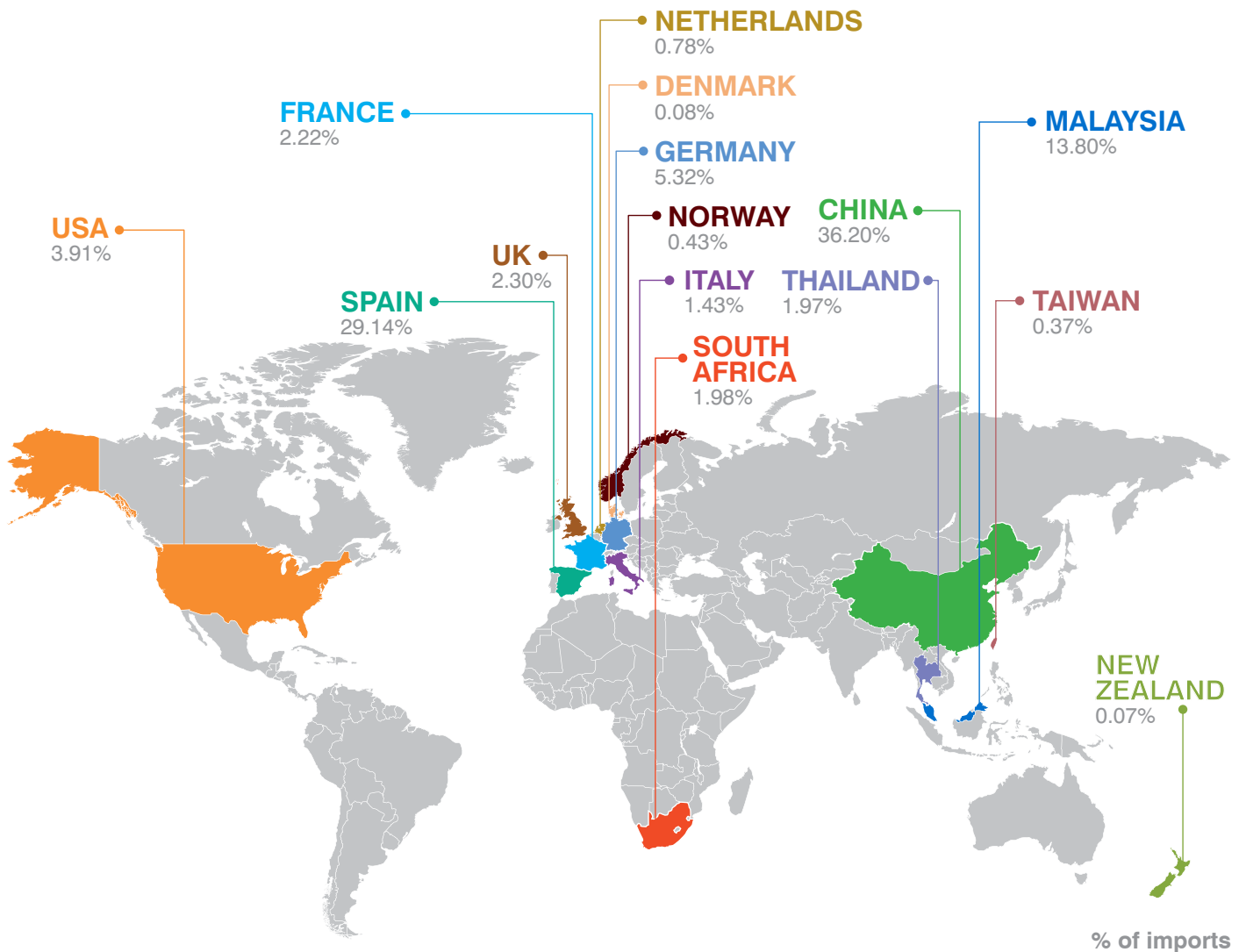

# Supply Chain/Vendor Information

Supply Chain/Vendor Category	Description of Goods or Services Provided by Vendor Category
<b>Sub-Contractors and Labour Hire Agencies</b>	Short to long-term contractors and labour hire workers such as manufacturing personnel, warehousing personnel, and officer personnel.
<b>Parts, Materials and Consumables Suppliers</b>	Tools, manufacturing components, consumable office supplies, re-seller products.
<b>Professional Services Consultants/Suppliers</b>	Legal consultancy, recruitment, test and calibration providers, training, and education providers.
<b>Facilities and Associated Utilities</b>	Lease providers, electricity, water, fuel, gas providers.
<b>Uniforms and PPE Suppliers</b>	Employee uniform and PPE providers.
<b>IT Service Providers/Suppliers</b>	Cloud based infrastructure IT Systems and Applications and Electronic Devices.

## Quantity of Vendors in Supplier Category

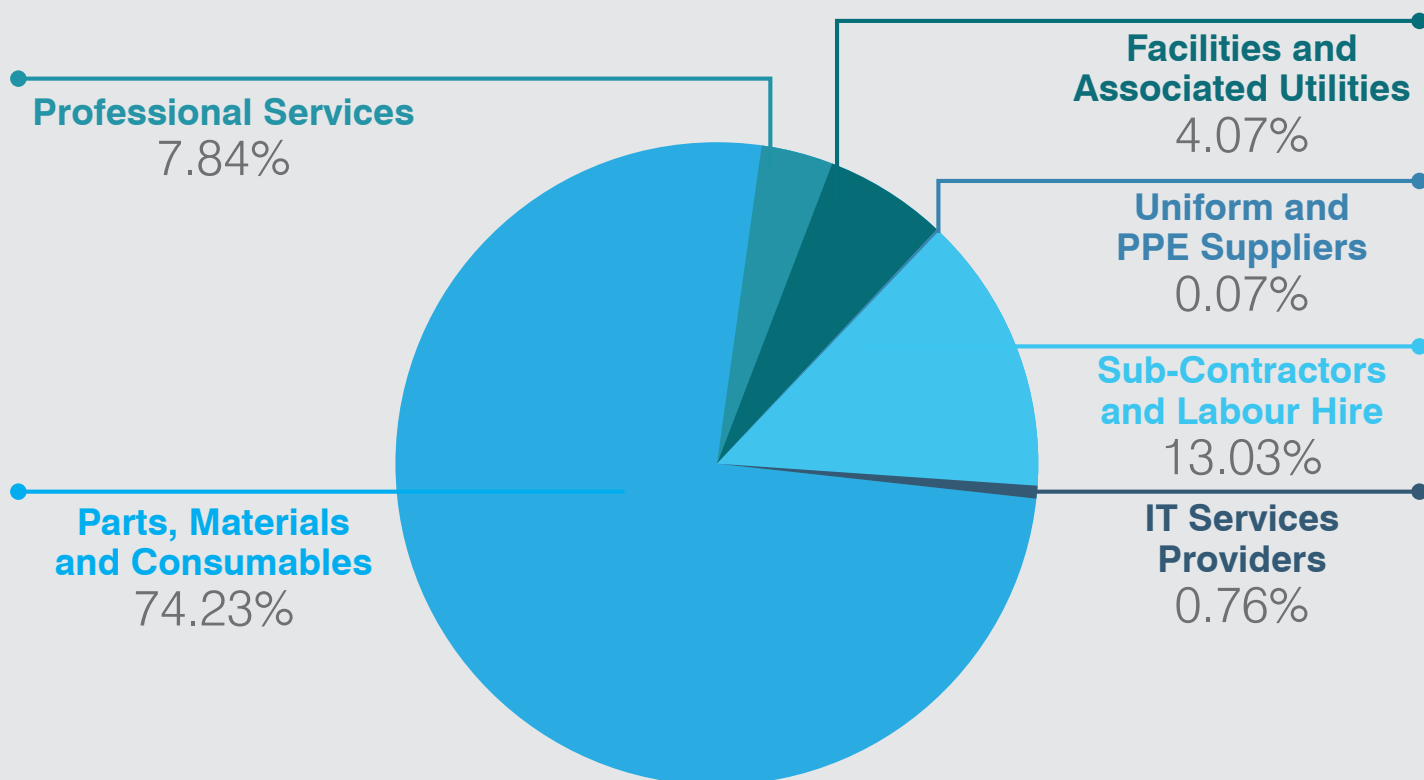

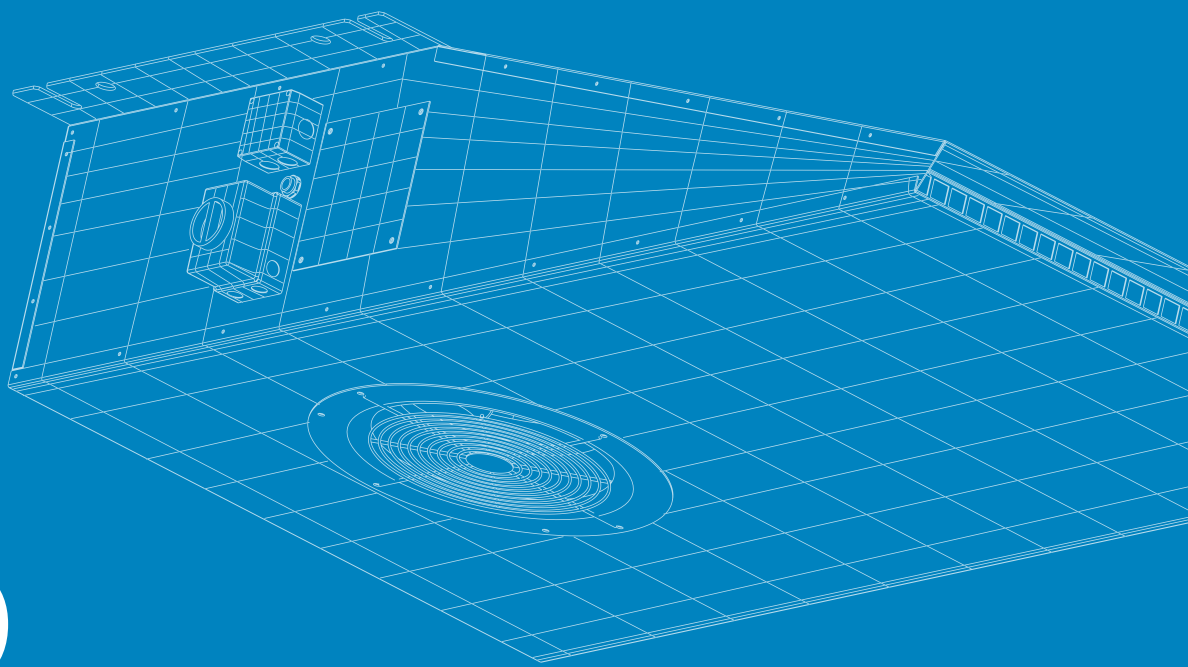

# 05

## IDENTIFYING RISKS OF MODERN SLAVERY IN OUR SUPPLY CHAIN

### Risk Indicators

The following indicators are reviewed to ensure potential modern slavery risks have been identified:

Type of Risk	Indicator
<b>Sector and Industry Risks</b>	Certain sectors and industries may have high modern slavery risks because of their characteristics, products, and processes.
<b>Product and Services Risk</b>	Certain products and services may have high modern slavery risks because of the way they are produced, provided, or used.
<b>Geographic Risks</b>	Some countries may have higher risks of modern slavery due to poor governance, weak rule of law, conflict, migration flows and socio-economic factors such as poverty.
<b>Entity Risks</b>	Some entities may have modern slavery risks because they have poor governance structures, a record of treating workers poorly or committing human rights violations.
<b>Indicators of Modern Slavery</b>	A combination of these signs may indicate a person is in a situation of modern slavery and that further investigation and assessment is required.

[In the creation of the above risk indications, we have referred to the 'Global Slavery Index' to identify countries that may have an inherent high risk of modern slavery from a supply chain perspective].



# Risks in Our Operations and Supply Chain

Below summarises the risk of Modern Slavery within our workplace and supply chain:

Operations or Supply Chain Aspect	Business Activity	Inherent Risk Factors	Existing Controls	Risk Rating
<b>Employees - Office Based Roles</b>	<ul style="list-style-type: none"> <li>• Research and development</li> <li>• Sourcing</li> <li>• Marketing and promotion</li> <li>• Sales</li> </ul>	<p>Working conditions including:</p> <ul style="list-style-type: none"> <li>• Hours of work</li> <li>• Rate of pay</li> <li>• Workplace amenities</li> <li>• Mental &amp; physical wellbeing</li> <li>• Workplace hygiene</li> </ul>	<ul style="list-style-type: none"> <li>• All employees are based in Australia and are subject to Australian Workplace and Employment Laws.</li> <li>• Employees are educated with regard to their rights through the provision of Fair Work content.</li> <li>• Australia has a low Global Slavery Index Score.</li> <li>• Office based work does not inherently give rise to modern slavery conditions.</li> <li>• Employee freely chooses employment.</li> <li>• Employees have the right and opportunity to report to relevant authorities and governing bodies.</li> <li>• The business have well established and thorough HR &amp; OHS policies, procedures, systems, and controls.</li> <li>• Employees are employed under modern awards and robust employment contracts.</li> <li>• The creation, implementation and training on the company Whistleblower Policy and reporting process.</li> <li>• Internal and external payroll audits and spot-checks.</li> <li>• Provision of Employee Assistance Program.</li> </ul>	Low
<b>Employees - Operational Based Roles</b>	<ul style="list-style-type: none"> <li>• Manufacturing</li> <li>• Warehousing</li> <li>• Distribution</li> </ul>	<p>Working conditions including:</p> <ul style="list-style-type: none"> <li>• Hours of work</li> <li>• Rate of pay</li> <li>• Workplace amenities</li> <li>• Mental &amp; physical wellbeing</li> <li>• Workplace hygiene</li> </ul>	<ul style="list-style-type: none"> <li>• All employees are based in Australia and are subject to Australian Workplace and Employment Laws.</li> <li>• Employee freely chooses employment.</li> <li>• Australia has a low Global Slavery Index Score.</li> <li>• Employees are educated with regard to their rights through the provision of Fair Work content.</li> <li>• Employees have the right and opportunity to report to relevant authorities and governing bodies.</li> <li>• The business Have well established and thorough HR &amp; OHS policies, procedures, systems, and controls.</li> <li>• Employees are employed under modern awards and robust employment contracts.</li> <li>• The creation, implementation and training on the company Whistleblower Policy and reporting process.</li> <li>• Provision of Employee Assistance Program.</li> <li>• Biometric time and attendance system.</li> </ul>	Low

Operations or Supply Chain Aspect	Business Activity	Inherent Risk Factors	Existing Controls	Risk Rating
<b>Sub-Contractor &amp; Labour Hire Workforce</b>	<ul style="list-style-type: none"> <li>• Manufacturing</li> <li>• Warehousing</li> <li>• Distribution</li> <li>• Administration</li> </ul>	<ul style="list-style-type: none"> <li>• Some contractor workers may have migrated from countries with a high Global Slavery Index Score and therefore may accept substandard working conditions and remuneration.</li> <li>• Some contractor workers may not be fluent in English to enable them to understand their rights or employment conditions</li> </ul>	<ul style="list-style-type: none"> <li>• All sub-contractors and labour hire workers are based in Australia and are subject to Australian workplace and employment laws.</li> <li>• Australia has a low Global Slavery Index Score.</li> <li>• Complete and thorough on-site company safety and job induction.</li> <li>• Robust subcontractor agreements with reference to modern awards.</li> <li>• The creation, implementation and training on the company Whistleblower Policy and reporting process.</li> <li>• Provision of Employee Assistance Program.</li> </ul>	Low
<b>Equipment, Parts and Materials and Other Service Suppliers</b>	Purchasing and Procurement	<ul style="list-style-type: none"> <li>• Geographical location of suppliers and/or manufacturing of products.</li> <li>• Unknown origin of raw materials or intermediate components.</li> <li>• Low margin and discounted products when purchasing a certain value.</li> <li>• Manufacturing and production of goods in countries rated highly on the Global Slavery Index.</li> <li>• Manufacturing and production of goods in countries that have poor rule of law and corrupt authority and services.</li> <li>• Manufacturing and production of goods in countries where comparatively to Australian standards, employees are subject to poor working conditions.</li> </ul>	<ul style="list-style-type: none"> <li>• All potential suppliers are reviewed prior to agreement being reached.</li> <li>• All potential suppliers are provided a copy of the Company 'Guide for Suppliers' including the details of expected business conduct, with reference to legal and ethical trade.</li> <li>• All potential suppliers are required to submit the Company 'Supplier Evaluation Form' whereby we address the risks of Modern Slavery and request the supplier provide information and context with regard to their actions taken to mitigate the risks of Modern Slavery with their business operations and supply chain.</li> <li>• Supplier visits are conducted periodically to strengthen the relationship between the company and supplier and to review the production of products and employee, contractor and labour hire working conditions.</li> <li>• The most at-risk geographic area of our supply chain is in China. To mitigate this risk, we have a local employee in China who conducts product inspections on site for each shipment. We plan to provide further training to this employee around identifying and reporting on modern slavery risks.</li> </ul>	Low to Moderate

# 06

## RISK MITIGATION, DUE DILIGENCE AND REMEDIATION PROCESSES

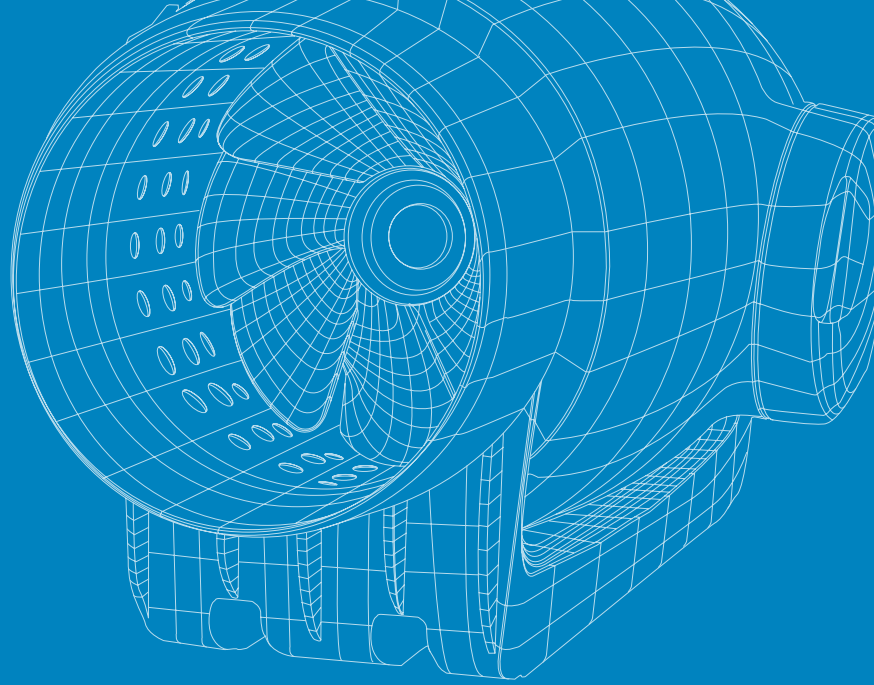

An overview of our risk management strategy including due diligence and the remediation process, for the current period and beyond is provided for below:

RISK MITIGATION/ CONTROL	2022 ACTIONS	➔ 2023 ACTIONS (Current Reporting Period)	➔ 2024 & BEYOND
<b>Risk Management Register</b>	Supply Chain Risk Management Register implemented to effectively audit and assess the risk of Modern Slavery with our supply chain.	A risk assessment framework developed along with a risk assessment register to report upon the level of risk within our supply chain and effectively address our suppliers and associated risks accordingly.	We will continue to periodically review the effectiveness of this register and ensure the appropriate record keeping of risk assessment data.
<b>Modern Slavery Committee</b>	Modern Slavery Committee was formed Implemented in 2022, meeting on a quarterly basis to address key compliance and continuous improvement actions.	The committee met on a quarterly basis and reviewed the actions required for the reporting period, as well as those committed to with regard to continuous improvement.	We will continue to convene the committee on a quarterly basis to ensure we are up to date with key compliance and continuous improvement actions.
<b>Leadership and Board Reporting</b>	We have implemented reporting on the risks of modern slavery in our supply chain within our end of year reporting requirements to business leaders and the board. The first report of this kind is due in December 2022.	Periodic reports regarding the risk of moderns slavery and business activity have been presented to the business and will continue to be presented during and at the end of reporting periods.	We will continue to report in the risks in our supply chain with regard to modern slavery and what actions we are taking to mitigate such risk.

RISK MITIGATION/ CONTROL	2022 ACTIONS	2023 ACTIONS (Current Reporting Period)	2024 & BEYOND
<b>Modern Slavery Supplier Questionnaire</b>	We have developed and implemented an automated supplier questionnaire through a cloud-based system allowing us to review and analyse reporting data more effectively.	The supplier questionnaire was reviewed and again distributed to suppliers to appropriately analyse and assess the risk in our supply chain. This questionnaire was accompanied with a Modern Slavery FAQ page for suppliers with regard to their obligations, our obligations, and our expectations of the relationship.	We will continue to review the questionnaire to ensure the questions are compliant and meaningful to the cause.
<b>Modern Slavery Act Compliance Framework</b>	Through discussion in the Modern Slavery Committee, we have identified the need to create a Modern Slavery Act Compliance Framework for our business.	We have finalised and implemented the Modern Slavery Act Compliance Framework by the middle of the next reporting period. This includes the Modern Slavery Committee and committee terms, risk assessments and our continuous improvement framework.	We intend to periodically review this framework to ensure it's effectiveness in reviewing and address the risk of Modern Slavery in our business operations and supply chain.
<b>Ethical Sourcing Policy and Questionnaires</b>	We have identified the need for a Company Ethical Sourcing Policy and correlation questions within our supplier application process. This will include a self-assessment checklist.	We aim to have created and implemented these items by the end of the next reporting period.	We intend to periodically review this policy and supplier questionnaire to ensure its effectiveness in reviewing and address the risk of Modern Slavery in our business operations and supply chain.
<b>Dispute and Grievance Resolution Policy</b>	<p>The companies Dispute and Grievance Resolution Policy is current with relevant and compliant legislation. The policy forms a part of the employee online induction with quiz and acknowledgement of understanding.</p> <p>To date, there have been no reported or potential risks identified of Modern Slavery.</p>	We have reviewed our dispute and grievance resolution policy in May of 2023 and found there were no required amendments to be made.	We will continue to review the effectiveness of our Dispute and Grievance Resolution Policy to ensure safe, and approachable ways for our employees, contractors, and suppliers to raise and address concerns.

RISK MITIGATION/ CONTROL	2022 ACTIONS	2023 ACTIONS (Current Reporting Period)	2024 & BEYOND
<b>Employee Training – Respect in the Workplace</b>	<p>The company undertakes by-yearly training regarding Respect in the Workplace which educates and informs of bullying, discrimination, and harassment. All employees must complete this training every 2 years and upon commencement with the company.</p> <p>When analysing the effectiveness of this training we review the participation rates, along with the number of matters raised through our Dispute and Grievance Resolution Process.</p>	<p>We have continued to train onboarding employees who are new to the business and have not previously completed the training on Respect in the Workplace, as a mandatory learning module in their induction and onboarding experience.</p>	<p>We aim to update this training to ensure we are presenting the most up to date and meaningful content.</p> <p>We will continue to conduct this training for all employees on a bi-yearly basis, as well as include the training in all new employees essential onboarding activities.</p>
<b>Code of Conduct</b>	<p>The companies Code of Conduct is current with relevant and compliant legislation. The Code of Conduct forms part of the employee online induction with quiz and acknowledgement of understanding.</p>	<p>The Code of Conduct was reviewed in May of 2023 and found there were no required amendments to be made.</p>	<p>The Code of Conduct is again due for a review in 2024, should amendments be made the Code of Conduct will be re-issued to all employees and updated on our online E-Learning system for induction purposes.</p>
<b>Whistleblower Policy</b>	<p>The companies Whistleblower Policy is current with relevant and compliant legislation. The Whistleblower Policy forms a part of the employee online induction with quiz and acknowledgement of understanding.</p> <p>To date, there have been no reported or potential risks identified of Modern Slavery.</p>	<p>The Whistleblower Policy was reviewed in May of 2023 and found there were no required amendments to be made.</p>	<p>The Whistleblower Policy is due for a review in 2024, should amendments be made the Whistleblower Policy will be re-issued to all employees and updated on our online E-Learning system for induction purposes.</p>
<b>Sub-Contractor Accreditation and Agreements</b>	<p>The company has agreements in place with all sub-contractor and labour hire vendors that detail minimum legal entitlements with reference to the applicable modern awards. The agreements also detail the rate of pay of the employee and the charge rate as to set out the wage rate being passed onto the contractor.</p>	<p>All sub-contractor and labour hire agreements were reviewed in line with Award CPI and amendments to the National Employment Standards, all agreements and conditions have been found to be compliant with at least the minimum requirements of employment under Australian Employment legislation.</p>	<p>We will continue to review any new sub-contractor and labour hire agreements as to ensure they are compliant with at least the minimum requirements of employment under Australian Employment legislation.</p>

RISK MITIGATION/ CONTROL	2022 ACTIONS	2023 ACTIONS (Current Reporting Period)	2024 & BEYOND
<b>Supplier Guide and Education</b>	A supplier guide is available for all potential and existing supplier of the company. The supplier guide refers to the acceptable business conduct and ethical trade.	The company has updated and re-issued the supplier guide to further expand of ethical trade and business, to also detail the risks of modern slavery in supply chain. This guide is available on the company intranet and provided to current and potential suppliers.	We aim to review the guide periodically and re-issue to further expand of ethical trade and business, to also detail the risks of modern slavery in supply chain.
<b>Supplier Approval Process</b>	The business currently reviews suppliers on an individual basis, addressing the risk of modern slavery without a documented approval process.	The company aims to create and implement a supplier approval process by the development of key supplier criteria including addressing the risk of modern slavery, as well as a correlating supplier form and approval framework.	The company in line with the creation of Supplier Agreements, is working with key personnel to create and implement an appropriate supplier approval process.
<b>Supplier Agreements</b>	The business currently enters supplier agreements on an individual basis without consistency across supplier agreements.	We have identified the requirement to build consistency with regard to our supplier agreements and modern slavery. As such, we aim to develop a standard agreement template that includes provisions regarding modern slavery risks, business expectations and ethical trade.	We are currently working with key personnel in our business as well as obtain external advice as to the creation and implementation of supplier agreements in specific relation to modern slavery.
<b>Awareness Training</b>	The business currently provides training on Modern Slavery in supply chain to those it is most applicable to. This is done through the verbal communication and handing down of information from Manager to direct report.	The business aims to develop a Modern Slavery E-Learning module for all employees to complete.	The business has created and implemented an e-learning module that has and will continue to be assigned for completion to all relevant personnel.
<b>Remediation Process</b>	The business thoroughly scopes the remediation process through the company Dispute and Grievance Resolution Policy.	We have reviewed our dispute and grievance resolution policy in May of 2023 and found there were no required amendments to be made.	The Dispute and Grievance Policy is due for a review in 2024, should amendments be made the Dispute and Grievance Resolution Policy will be re-issued to all employees and updated on our online E-Learning system for induction purposes.



# 07

## ASSESSING THE EFFECTIVENESS OF OUR ACTIONS

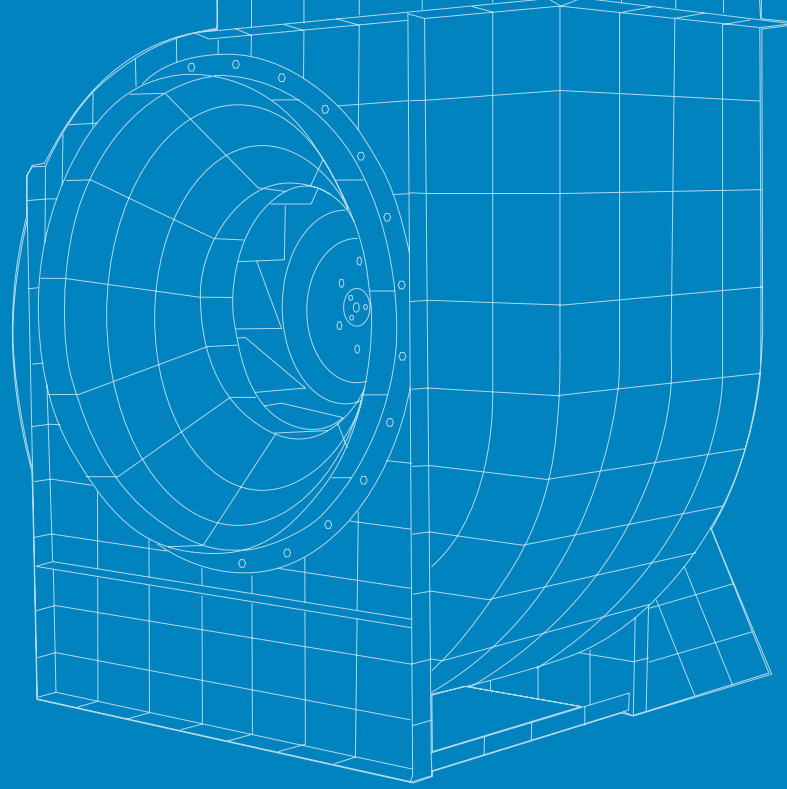

We will continue to assess the effectiveness of our actions taken to address modern slavery risks, how we will do this is summarised below:

Assessment Description	Method
<b>Criteria based and systemised approach to supplier and contractor engagement</b>	Creation of consistent documentation regarding the onboarding of new suppliers such as: <ul style="list-style-type: none"><li>• Agreement Templates</li><li>• Information Booklet/Guide</li><li>• Modern Slavery Questionnaire</li><li>• Supplier tender questionnaire</li></ul>
<b>Modern Slavery Risk Register Reviews &amp; Assessments</b>	Conduct an annual Modern Slavery Risk Register review to: <ul style="list-style-type: none"><li>• Amend risk context and rating where applicable</li><li>• Review new risks</li><li>• Review planned or existing mitigation actions and effectiveness</li></ul>
<b>Annual Review of Policies and Procedures</b>	Review, amend and/or update all relevant company policy and procedure to ensure the most up to date and relevant information is documented. If amended, recommunicate revised policies and procedures.
<b>Whistle-Blower Grievances</b>	Periodically review the effectiveness of any actions taken as a result of a whistle-blower grievance as related to modern slavery concerns.
<b>Supplier Reviews</b>	Conduct periodic supplier and sub-contractor reviews in line with agreements and report instances of non-compliance and areas for improvement.
<b>Internal Reporting</b>	Report on the state of modern slavery risk management to the executive leadership team and the board.

# 08

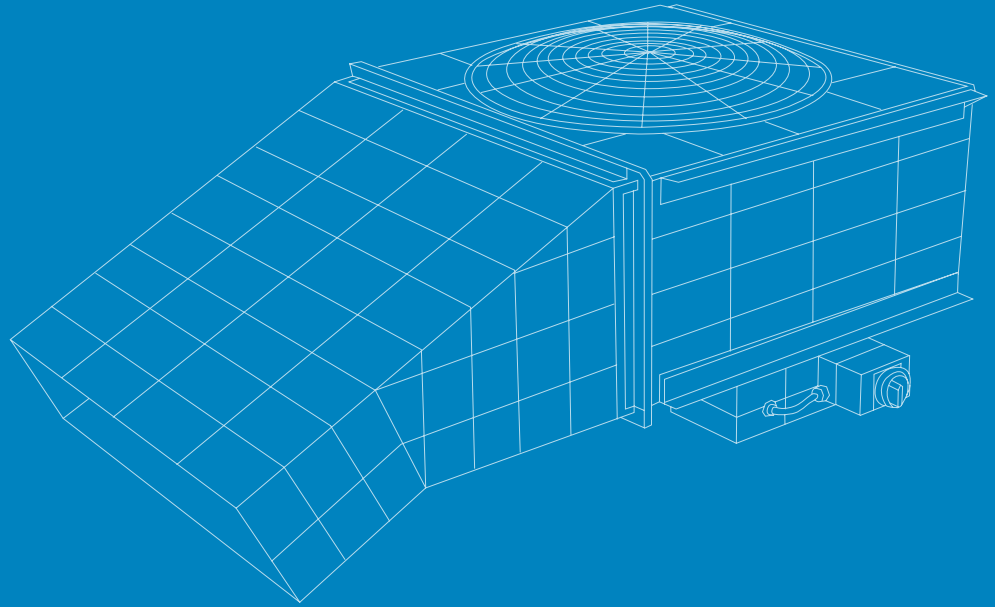

## OUR PLANS FOR CONTINUOUS IMPROVEMENT

We recognise the importance of continuous improvement in order to make contributions and understand this statement is a continuous ‘work in progress’ year on year. To meaningfully contribute to the fight against Modern Slavery we have developed key areas of focus for the next reporting periods in addition to the ‘planned actions’ set out within our risk mitigation and due diligence table:

### Future State – Addressing Modern Slavery Risks

#### 2023 & Beyond

##### Compliance

- Produce and publish our next ‘Modern Slavery Statement’ for the 2023/2024 reporting period in accordance with statutory obligations.

##### Education & Training

- Continue our engagement with our supplier and subcontractors in regard to their compliance with the Modern Slavery Act and conduct formal reviews of our suppliers and subcontractors.
- Employee training on Modern Slavery via e-learning module.
- Continue to facilitate appropriate modern slavery awareness training sessions to relevant employees.
- Update and issue the Company Supplier Guide further expanding on Modern Slavery and ethical business practices, in line with company expectations of reporting and remediation.

##### Internal & External Policy & Procedure

- Ongoing monitoring of internal policies and procedures for managing risks of modern slavery practices throughout our supply chain and assessing its effectiveness of our risk control strategy and associated operational procedures.
- Creation and implementation companywide of a Modern Slavery and Ethical Sourcing Policy.

##### Due Diligence, Mitigation & Remediation

- We will capture and address any reported change to the risk profile of our suppliers in relation to modern slavery, as required by our Supplier / Subcontractor code of conduct.
- Remain vigilant to any occurrences of modern slavery by capturing any reported incidents of modern slavery within the company supply chain and investigate.
- Continue to meet and expand the Modern Slavery Committee to continually improve our company framework and response.

# 09

## CONSULTATION

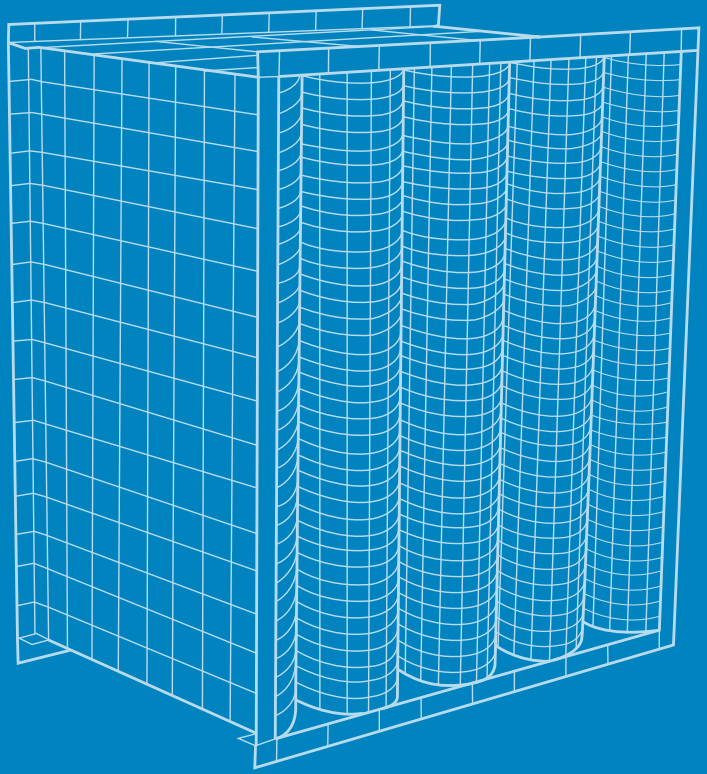

We recognise the importance of collaborative and cross-functional approach to addressing the risks of Modern Slavery in our workplace and supply chain, as such the Modern Slavery Committee was established.

This statement was prepared in consultation and collaboration within the Modern Slavery Committee comprised of Fantech Pty Ltd key personnel such as Directors, Senior Procurement and Supply Chain employees, Human Resources, the responsible persons for assets and maintenance, Information Technology and Senior Operations Personnel. Within this consultation, we reviewed and discussed the current company practices relating to Modern Slavery Risks and how we can commit to improvements.

# 10

## APPROVAL

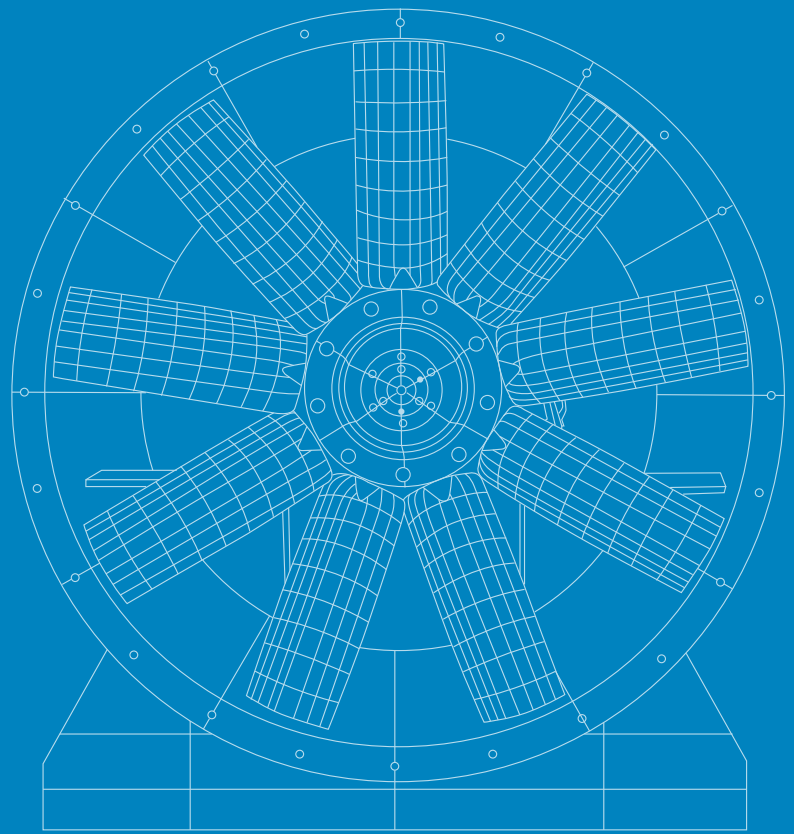

This Modern Slavery Statement is approved by the principal governing body for FANTECH PTY LTD. This statement is made pursuant to section 13(1) of Modern Slavery Act 2018 (Cth). It constitutes the statement of the aforementioned businesses for the year ended 30 June 2023.

Handwritten signature of Anthony Lamaro

9/8/23

Anthony Lamaro  
Managing Director  
FANTECH PTY LTD